

**Features**

- **SuperFAST HIGH DENSITY PROGRAMMABLE LOGIC**
  - 4000 PLD Gates
  - 96 I/O Pins, Six Dedicated Inputs
  - 96 Registers
  - High Speed Global Interconnect
  - Wide Input Gating for Fast Counters, State Machines, Address Decoders, etc.
  - Small Logic Block Size for Random Logic
  - 100% Functional, JEDEC and Pinout Compatible with ispLSI 2096V Devices
  - Pinout Compatible with ispLSI 2192VE
- **3.3V LOW VOLTAGE 2096 ARCHITECTURE**
  - Interfaces with Standard 5V TTL Devices
- **HIGH PERFORMANCE E<sup>2</sup>CMOS<sup>®</sup> TECHNOLOGY**
  - $f_{max} = 180$  MHz Maximum Operating Frequency
  - $t_{pd} = 5.0$  ns Propagation Delay
  - Electrically Erasable and Reprogrammable
  - Non-Volatile
  - 100% Tested at Time of Manufacture
  - Unused Product Term Shutdown Saves Power
- **IN-SYSTEM PROGRAMMABLE**
  - 3.3V In-System Programmability (ISP™) Using Boundary Scan Test Access Port (TAP)
  - Open-Drain Output Option for Flexible Bus Interface Capability, Allowing Easy Implementation of Wired-OR or Bus Arbitration Logic
  - Increased Manufacturing Yields, Reduced Time-to-Market and Improved Product Quality
  - Reprogram Soldered Devices for Faster Prototyping
- **100% IEEE 1149.1 BOUNDARY SCAN TESTABLE**
- **THE EASE OF USE AND FAST SYSTEM SPEED OF PLDs WITH THE DENSITY AND FLEXIBILITY OF FPGAs**
  - Enhanced Pin Locking Capability
  - Three Dedicated Clock Input Pins
  - Synchronous and Asynchronous Clocks
  - Programmable Output Slow Rate Control
  - Flexible Pin Placement
  - Optimized Global Routing Pool Provides Global Interconnectivity
- **ispEXPERT™ – LOGIC COMPILER AND COMPLETE ISP DEVICE DESIGN SYSTEMS FROM HDL SYNTHESIS THROUGH IN-SYSTEM PROGRAMMING**
  - Superior Quality of Results
  - Tightly Integrated with Leading CAE Vendor Tools
  - Productivity Enhancing Timing Analyzer, Explore Tools, Timing Simulator and ispANALYZER™
  - PC and UNIX Platforms

**Functional Block Diagram**

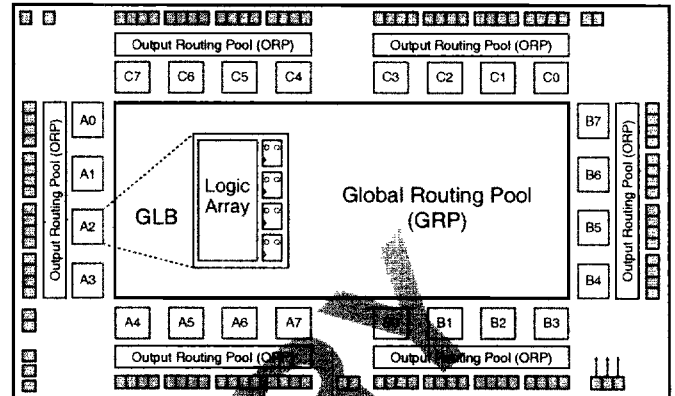

**Description**

The ispLSI 2096VE is a High Density Programmable Logic Device containing 96 Registers, six Dedicated Input pins, three Dedicated Clock Input pins, two dedicated Global I/O input pins and a Global Routing Pool (GRP). The GRP provides complete interconnectivity between all of these elements. The ispLSI 2096VE features in-system programmability through the Boundary Scan Test Access Port (TAP) and is 100% IEEE 1149.1 Boundary Scan Testable. The ispLSI 2096VE offers non-volatile reprogrammability of the logic, as well as the interconnect to provide truly reconfigurable systems.

The basic unit of logic on the ispLSI 2096VE device is the Generic Logic Block (GLB). The GLBs are labeled A0, A1 .. C7 (see Figure 1). There are a total of 24 GLBs in the ispLSI 2096VE device. Each GLB is made up of four macrocells. Each GLB has 18 inputs, a programmable AND/OR/Exclusive OR array, and four outputs which can be configured to be either combinatorial or registered. Inputs to the GLB come from the GRP and dedicated inputs. All of the GLB outputs are brought back into the GRP so that they can be connected to the inputs of any GLB on the device.

The devices also have 96 I/O cells, each of which is directly connected to an I/O pin. Each I/O cell can be individually programmed to be a combinatorial input, output or bi-directional I/O pin with 3-state control. The signal levels are TTL compatible voltages and the output drivers can source 4 mA or sink 8 mA. Each output can

Copyright © 1999 Lattice Semiconductor Corp. All brand or product names are trademarks or registered trademarks of their respective holders. The specifications and information herein are subject to change without notice.

**Functional Block Diagram**

Figure 1. ispLSI 2096VE Functional Block Diagram

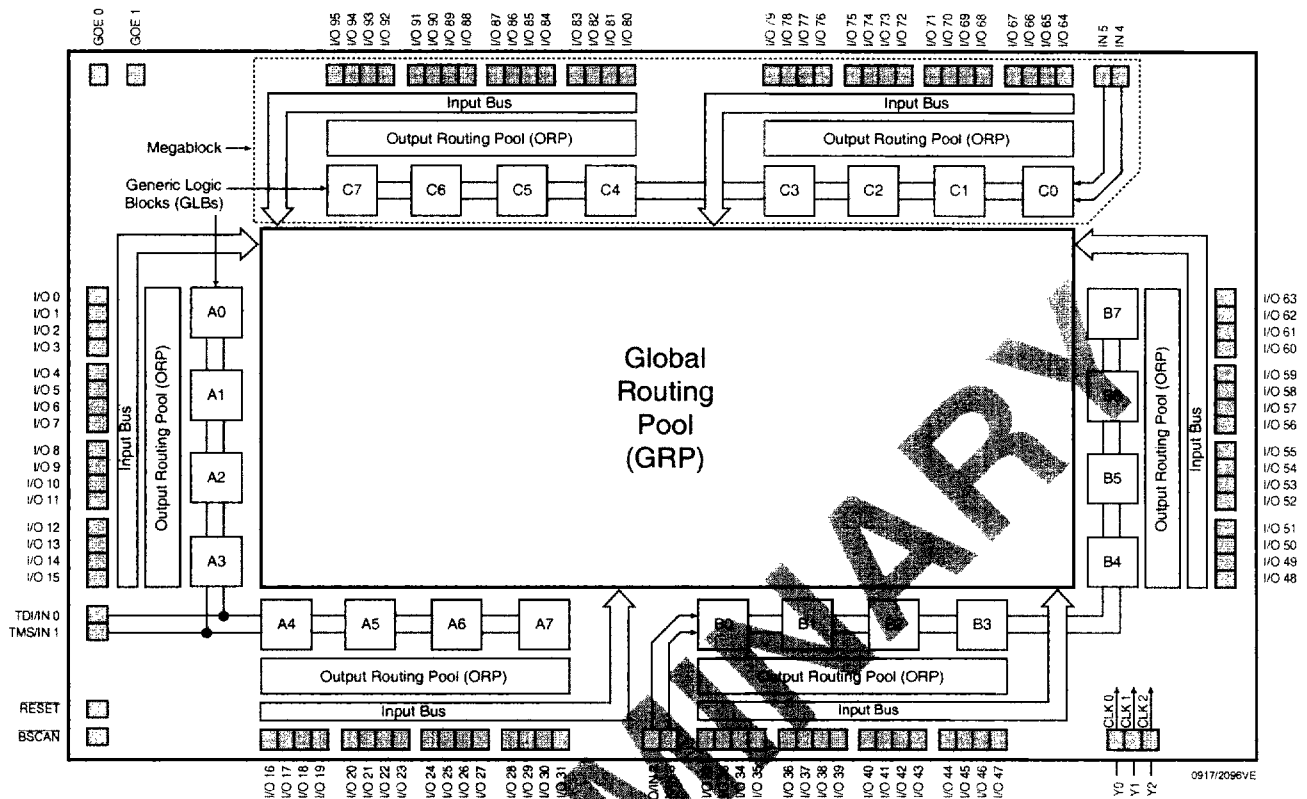

be programmed independently for fast or slow output slew rate to minimize overall output switching noise. Device pins can be safely driven to 5V signal levels to support mixed-voltage systems.

Eight GLBs, 32 I/O cells, two dedicated inputs and two ORPs are connected together to make a Megablock (see Figure 1). The outputs of the eight GLBs are connected to a set of 32 universal I/O cells by the two ORPs. Each ispLSI 2096VE device contains three Megablocks.

The GRP has 32 inputs, the outputs from all of the GLBs and all of the inputs from the bi-directional I/O cells. All of these signals are made available to the inputs of the GLBs. Delays through the GRP have been equalized to minimize timing skew.

Clocks in the ispLSI 2096VE device are selected using the dedicated clock pins. Three dedicated clock pins (Y0, Y1, Y2) or an asynchronous clock can be selected on a GLB basis. The asynchronous or Product Term clock can be generated in any GLB for its own clock.

**Programmable Open-Drain Outputs**

In addition to the standard output configuration, the outputs of the ispLSI 2096VE are individually programmable, either as a standard totem-pole output or an open-drain output. The totem-pole output drives the specified Voh and Vol levels, whereas the open-drain output drives only the specified Vol. The Voh level on the open-drain output depends on the external loading and pull-up. This output configuration is controlled by a programmable fuse. The default configuration when the device is in bulk erased state is totem-pole configuration. The open-drain/totem-pole option is selectable through the ispEXPERT software tools.

## Absolute Maximum Ratings <sup>1</sup>

Supply Voltage $V_{CC}$ .....	-0.5 to +5.4V
Input Voltage Applied .....	-0.5 to +5.6V
Off-State Output Voltage Applied .....	-0.5 to +5.6V
Storage Temperature .....	-65 to 150°C
Case Temp. with Power Applied .....	-55 to 125°C
Max. Junction Temp. ( $T_J$ ) with Power Applied ...	150°C

1. Stresses above those listed under the "Absolute Maximum Ratings" may cause permanent damage to the device. Functional operation of the device at these or at any other conditions above those indicated in the operational sections of this specification is not implied (while programming, follow the programming specifications).

## DC Recommended Operating Condition

SYMBOL	PARAMETER	MIN.	MAX.	UNITS	
$V_{CC}$	Supply Voltage	Commercial $T_A = 0^\circ\text{C}$ to $70^\circ\text{C}$	3.0	3.6	V
		Industrial $T_A = -40^\circ\text{C}$ to $105^\circ\text{C}$	3.0	3.6	V
$V_{IL}$	Input Low Voltage	$V_{SS} - 0.5$	0.8	V	
$V_{IH}$	Input High Voltage	2.0	5.25	V	

Table 2-0005/2096VE

## Capacitance ( $T_A = 25^\circ\text{C}$ , $f = 1.0\text{ MHz}$ )

SYMBOL	PARAMETER	TYPICAL	UNITS	TEST CONDITIONS
$C_1$	Dedicated Input Capacitance	8	pf	$V_{CC} = 3.3\text{V}$ , $V_{IN} = 2.0\text{V}$
$C_2$	I/O Capacitance	6	pf	$V_{CC} = 3.3\text{V}$ , $V_{I/O} = 2.0\text{V}$
$C_3$	Clock and Global Output Enable Capacitance	10	pf	$V_{CC} = 3.3\text{V}$ , $V_Y = 2.0\text{V}$

Table 2-0006/2096VE

## Erase Reprogram Specifications

PARAMETER	MINIMUM	MAXIMUM	UNITS
Erase/Reprogram Cycle	10000	—	Cycles

Table 2-0008/2096VE

## Switching Test Conditions

Input Pulse Levels	GND to 3.0V
Input Rise and Fall Time	≤ 1.5ns 10% to 90%
Input Timing Reference Levels	1.5V
Output Timing Reference Levels	1.5V
Output Load	See Figure 2

3-state levels are measured 0.5V from steady-state active level.

Table 2-0003/2096VE

Figure 2. Test Load

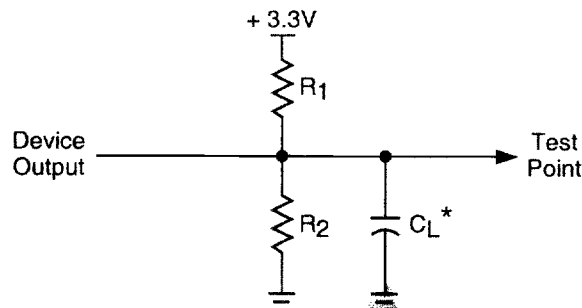

\*  $C_L$  includes Test Fixture and Probe Capacitance.

0213A/2096VE

## Output Load Conditions (see Figure 2)

TEST CONDITION		R1	R2	CL
A		316Ω	348Ω	35pF
B	Active High	∞	348Ω	35pF
	Active Low	316Ω	348Ω	35pF
C	Active High to Z at $V_{OH}-0.5V$	∞	348Ω	5pF
	Active Low to Z at $V_{OL}+0.5V$	316Ω	348Ω	5pF

Table 2-0004/2096VE

## DC Electrical Characteristics

### Over Recommended Operating Conditions

SYMBOL	PARAMETER	CONDITION	MIN.	TYP. <sup>3</sup>	MAX.	UNITS
$V_{OL}$	Output Low Voltage	$I_{OL} = 8\text{ mA}$	–	–	0.4	V
$V_{OH}$	Output High Voltage	$I_{OH} = 8\text{ mA}$	2.4	–	–	V
$I_{IL}$	Input or I/O Low Leakage Current	$0V \leq V_{IN} \leq V_{IL}(\text{Max.})$	–	–	-10	μA
$I_{IH}$	Input or I/O High Leakage Current	$(V_{CC} - 0.2)V \leq V_{IN} \leq V_{CC}$ $V_{CC} \leq V_{IN} \leq 5.25V$	–	–	10	μA
$I_{IL-isp}$	BSCAN Input Low Leakage Current	$0V \leq V_{IN} \leq V_{IL}$	–	–	-150	μA
$I_{IL-PU}$	I/O Active Pull-Up Current	$0V \leq V_{IN} \leq V_{IL}$	–	–	-150	μA
$I_{OS}^1$	Output Short Circuit Current	$V_{CC} = 3.3V, V_{OUT} = 0.5V$	–	–	-100	mA
$I_{CC}^{2,4}$	Operating Power Supply Current	$V_{IL} = 0.0V, V_{IH} = 3.0V$ $f_{CLOCK} = 1\text{ MHz}$	–	–	–	mA

Table 2-0007A/2096VE

- One output at a time for a maximum duration of one second.  $V_{OUT} = 0.5V$  was selected to avoid test problems by tester ground degradation. Characterized but not 100% tested.
- Measured using six 16-bit counters.
- Typical values are at  $V_{CC} = 3.3V$  and  $T_A = 25^\circ C$ .
- Maximum  $I_{CC}$  varies widely with specific device configuration and operating frequency. Refer to the Power Consumption section of this data sheet and Thermal Management section of the Lattice Semiconductor Data Book or CD-ROM to estimate maximum  $I_{CC}$ .

**External Timing Parameters**

**Over Recommended Operating Conditions**

PARAMETER	TEST COND. <sup>3</sup>	#	DESCRIPTION <sup>1</sup>	-180		-135		-100		UNITS
				MIN.	MAX.	MIN.	MAX.	MIN.	MAX.	
t <sub>pd1</sub>	A	1	Data Propagation Delay, 4PT Bypass, ORP Bypass	-	5.0	-	7.5	-	10.0	ns
t <sub>pd2</sub>	A	2	Data Propagation Delay	-	7.5	-	10.0	-	13.0	ns
f <sub>max</sub>	A	3	Clock Frequency with Internal Feedback <sup>2</sup>	180	-	135	-	100	-	MHz
f <sub>max</sub> (Ext.)	-	4	Clock Frequency with External Feedback ( $\frac{1}{t_{su2} + t_{co1}}$ )	125	-	100	-	77	-	MHz
f <sub>max</sub> (Tog.)	-	5	Clock Frequency, Max. Toggle	200	-	143	-	100	-	MHz
t <sub>su1</sub>	-	6	GLB Reg. Setup Time before Clock, 4 PT Bypass	3.5	-	5.0	-	6.5	-	ns
t <sub>co1</sub>	A	7	GLB Reg. Clock to Output Delay, ORP Bypass	-	3.5	-	4.0	-	5.0	ns
t <sub>h1</sub>	-	8	GLB Reg. Hold Time after Clock, 4 PT Bypass	0.0	-	0.0	-	0.0	-	ns
t <sub>su2</sub>	-	9	GLB Reg. Setup Time before Clock	4.5	-	6.0	-	8.0	-	ns
t <sub>co2</sub>	A	10	GLB Reg. Clock to Output Delay	-	5.0	-	5.0	-	6.0	ns
t <sub>h2</sub>	-	11	GLB Reg. Hold Time after Clock	0.0	-	0.0	-	0.0	-	ns
t <sub>r1</sub>	A	12	Ext. Reset Pin to Output Delay	-	7.0	-	10.0	-	13.5	ns
t <sub>rw1</sub>	-	13	Ext. Reset Pulse Duration	4.0	-	5.0	-	6.5	-	ns
t <sub>ptoen</sub>	B	14	Input to Output Enable	-	10.0	-	12.0	-	15.0	ns
t <sub>ptoedis</sub>	C	15	Input to Output Disable	-	10.0	-	12.0	-	15.0	ns
t <sub>goeen</sub>	B	16	Global OE Output Enable	-	5.0	-	7.0	-	9.0	ns
t <sub>goedis</sub>	C	17	Global OE Output Disable	-	5.0	-	7.0	-	9.0	ns
t <sub>wh</sub>	-	18	External Synchronous Clock Pulse Duration, High	2.5	-	3.5	-	5.0	-	ns
t <sub>wl</sub>	-	19	External Synchronous Clock Pulse Duration, Low	2.5	-	3.5	-	5.0	-	ns

Table 2-0030/2096VE

1. Unless noted otherwise, all parameters use a GRP load (Y0 or 20 PTXOR path, ORP and Y0 clock).
2. Standard 16-bit counter using GRP feedback.
3. Reference Switching Test Conditions section.

PRELIMINARY

**Internal Timing Parameters<sup>1</sup>**

**Over Recommended Operating Conditions**

PARAMETER	# <sup>2</sup>	DESCRIPTION	-180		-135		-100		UNITS
			MIN.	MAX.	MIN.	MAX.	MIN.	MAX.	
<b>Inputs</b>									
t <sub>io</sub>	20	Input Buffer Delay	-	-	-	-	-	-	ns
t <sub>din</sub>	21	Dedicated Input Delay	-	-	-	-	-	-	ns
<b>GRP</b>									
t <sub>grp</sub>	22	GRP Delay	-	-	-	-	-	-	ns
<b>GLB</b>									
t <sub>4ptbpc</sub>	23	4 Product Term Bypass Path Delay (Combinatorial)	-	-	-	-	-	-	ns
t <sub>4ptbpr</sub>	24	4 Product Term Bypass Path Delay (Registered)	-	-	-	-	-	-	ns
t <sub>1ptxor</sub>	25	1 Product Term/XOR Path Delay	-	-	-	-	-	-	ns
t <sub>20ptxor</sub>	26	20 Product Term/XOR Path Delay	-	-	-	-	-	-	ns
t <sub>xoradj</sub>	27	XOR Adjacent Path Delay <sup>3</sup>	-	-	-	-	-	-	ns
t <sub>gbp</sub>	28	GLB Register Bypass Delay	-	-	-	-	-	-	ns
t <sub>gsu</sub>	29	GLB Register Setup Time before Clock	-	-	-	-	-	-	ns
t <sub>gh</sub>	30	GLB Register Hold Time after Clock	-	-	-	-	-	-	ns
t <sub>gco</sub>	31	GLB Register Clock to Output Delay	-	-	-	-	-	-	ns
t <sub>gro</sub>	32	GLB Register Reset to Output Delay	-	-	-	-	-	-	ns
t <sub>ptre</sub>	33	GLB Product Term Reset to Register Delay	-	-	-	-	-	-	ns
t <sub>ptoe</sub>	34	GLB Product Term Output Enable to I/O Cell Delay	-	-	-	-	-	-	ns
t <sub>ptck</sub>	35	GLB Product Term Clock Delay	-	-	-	-	-	-	ns
<b>ORP</b>									
t <sub>orp</sub>	36	ORP Delay	-	-	-	-	-	-	ns
t <sub>orpbp</sub>	37	ORP Bypass Delay	-	-	-	-	-	-	ns
<b>Outputs</b>									
t <sub>ob</sub>	38	Output Buffer Delay	-	-	-	-	-	-	ns
t <sub>sl</sub>	39	Output Signal Limit Delay Adder	-	-	-	-	-	-	ns
t <sub>oen</sub>	40	I/O Cell OE to Output Enabled	-	-	-	-	-	-	ns
t <sub>odis</sub>	41	I/O Cell OE to Output Disabled	-	-	-	-	-	-	ns
t <sub>goe</sub>	42	Global Output Enable	-	-	-	-	-	-	ns
<b>Clocks</b>									
t <sub>gy0</sub>	43	Clock Delay, Y0 to Global GLB Clock Line (Ref. clock)	-	-	-	-	-	-	ns
t <sub>gy1/2</sub>	44	Clock Delay, Y1 or Y2 to Global GLB Clock Line	-	-	-	-	-	-	ns
<b>Global Reset</b>									
t <sub>gr</sub>	45	Global Reset to GLB	-	-	-	-	-	-	ns

Table 2-0036/2096VE

- Internal Timing Parameters are not tested and are for reference only.
- Refer to Timing Model in this data sheet for further details.
- The XOR adjacent path can only be used by hard macros.

**ispLSI 2096VE Timing Model**

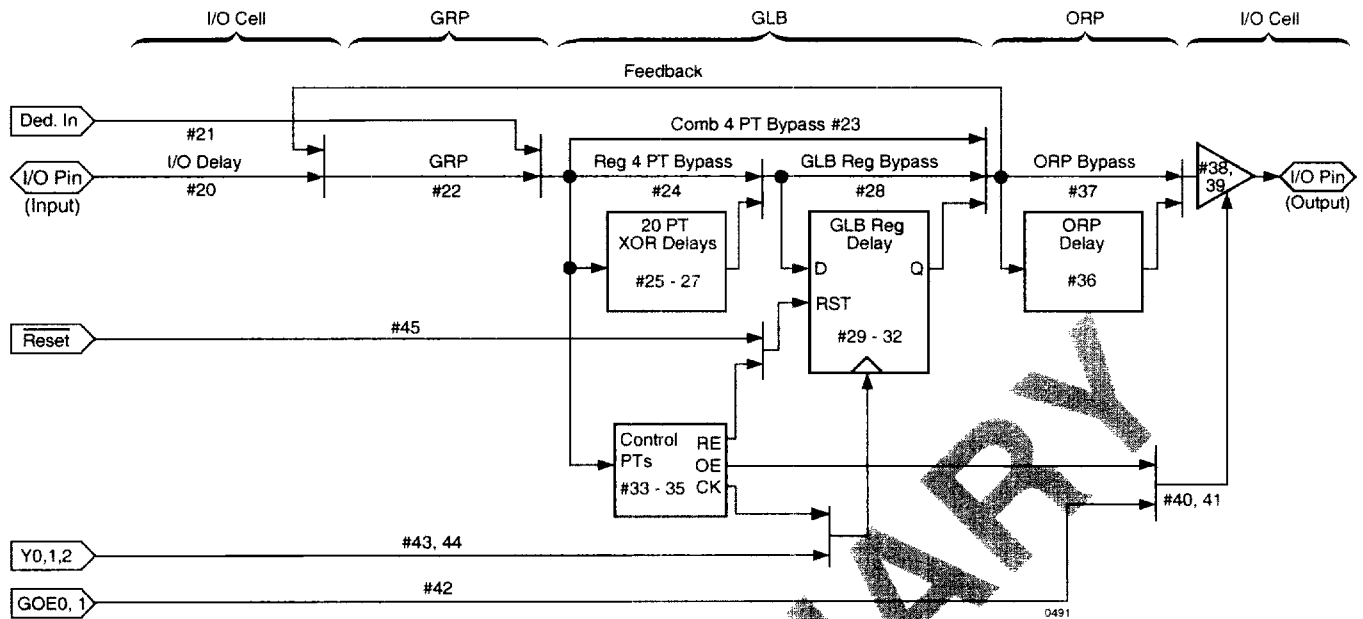

**Derivations of  $t_{su}$ ,  $t_h$  and  $t_{co}$  from the Product Term Clock**

$$\begin{aligned}
 t_{su} &= \text{Logic} + \text{Reg } s_u - \text{Clock (min)} \\
 &= (t_{io} + t_{grp} + t_{20ptxor}) + (t_{gsu}) - (t_{io} + t_{grp} + t_{ptck(min)}) \\
 &= (\#20 + \#22 + \#26) + (\#29) - (\#20 + \#22 + \#35) \\
 \\
 t_h &= \text{Clock (max)} + \text{Reg } h - \text{Logic} \\
 &= (t_{io} + t_{grp} + t_{ptck(max)}) + (t_{gh}) - (t_{io} + t_{grp} + t_{20ptxor}) \\
 &= (\#20 + \#22 + \#35) + (\#30) - (\#20 + \#22 + \#26) \\
 \\
 t_{co} &= \text{Clock (max)} + \text{Reg } c_o - \text{Output} \\
 &= (t_{io} + t_{grp} + t_{ptck(max)}) + (t_{gco}) + (t_{orp} + t_{ob}) \\
 &= (\#20 + \#22 + \#35 + \#31) + (\#36 + \#38)
 \end{aligned}$$

Note: Calculations are based upon timing specifications for the ispLSI 2096VE-180L.

Table 2-0042/2096VE

**Power Consumption**

Power consumption in the ispLSI 2096VE device depends on two primary factors: the speed at which the device is operating and the number of Product Terms

used. Figure 3 shows the relationship between power and operating speed.

**Figure 3. Typical Device Power Consumption vs fmax**

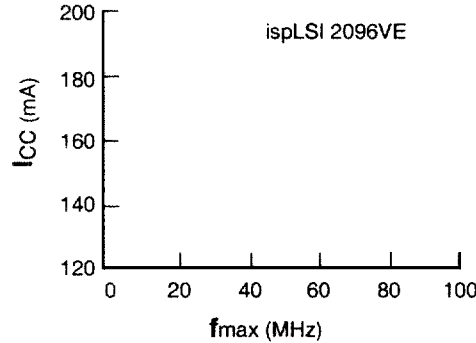

Notes: Configuration of six 16-bit counters  
Typical current at 3.3V, 25° C

ICC can be estimated for the ispLSI 2096VE using the following equation:

$$I_{CC} \text{ (mA)} =$$

Where:

- # of PTs = Number of Product Terms used in design
- # of nets = Number of Signals used in device
- Max freq = Highest Clock Frequency to the device (in MHz)

The ICC estimate is based on typical conditions (VCC = 3.3V, room temperature) and an assumption of two GLB loads on average exists. These values are for estimates only. Since the value of ICC is sensitive to operating conditions and the program in the device, the actual ICC should be verified.

0127/2096VE

PRELIMINARY



## Pin Description

NAME	PQFP & TQFP PIN NUMBERS	DESCRIPTION
I/O 0 - I/O 5 I/O 6 - I/O 11 I/O 12 - I/O 17 I/O 18 - I/O 23 I/O 24 - I/O 29 I/O 30 - I/O 35 I/O 36 - I/O 41 I/O 42 - I/O 47 I/O 48 - I/O 53 I/O 54 - I/O 59 I/O 60 - I/O 65 I/O 66 - I/O 71 I/O 72 - I/O 77 I/O 78 - I/O 83 I/O 84 - I/O 89 I/O 90 - I/O 95	21, 22, 23, 24, 25, 26 27, 28, 29, 30, 32, 33 35, 36, 37, 38, 39, 40 41, 42, 43, 44, 45, 46 51, 52, 53, 54, 55, 56 57, 58, 59, 60, 61, 62 64, 65, 67, 68, 69, 70 71, 72, 73, 74, 75, 76 85, 86, 87, 88, 89, 90 91, 92, 93, 94, 96, 97 99, 100, 101, 102, 103, 104 105, 106, 107, 108, 109, 110 115, 116, 117, 118, 119, 120 121, 122, 123, 124, 125, 126 128, 1, 3, 4, 5, 6 7, 8, 9, 10, 11, 12	Input/Output Pins - These are the general purpose I/O pins used by the logic array.
GOE 0, GOE 1	80, 17	Global Output Enables input pins.
IN 4, IN 5	84, 113	Dedicated input pins to the device.
BSCAN	19	Input — Dedicated in-system programming Boundary Scan enable input pin. This pin is brought out to enable the programming mode. The TMS, TDI, TDO and TCK controls become active.
TDI/IN 0	20	Input — This pin performs two functions. When BSCAN is logic low, it functions as a serial data input pin to load programming data into the device. When BSCAN is high, it functions as a dedicated input pin.
TMS/IN 1	48	Input — This pin performs two functions. When BSCAN is logic low, it functions as a mode control pin for the ISP/Boundary Scan state machine. When BSCAN is high, it functions as a dedicated input pin.
TDO/IN 2	112	Input/output — This pin performs two functions. When BSCAN is logic low, it functions as an output pin to read serial shift register data. When BSCAN is high, it functions as a dedicated input pin.
TCK/IN 3	77	Input — This pin performs two functions. When BSCAN is logic low, it functions as a clock pin for the ISP/Boundary Scan state machine. When BSCAN is high, it functions as a dedicated input pin.
RESET	15	Active Low (0) Reset pin which resets all of the GLB and I/O registers in the device.
Y0, Y1, Y2	14, 83, 71	Dedicated Clock input. This clock input is connected to one of the clock inputs of all the GLBs on the device.
GND	18, 34, 50, 63, 79, 98, 111, 127	Ground (GND)
VCC	2, 16, 31, 47, 66, 81, 95	V <sub>CC</sub>
NC <sup>1</sup>	13, 49, 82	No Connect.

1. NC pins are not to be connected to any active signal, VCC or GND.

**Pin Configuration**

ispLSI 2096VE 128-Pin PQFP and TQFP Pinout Diagram

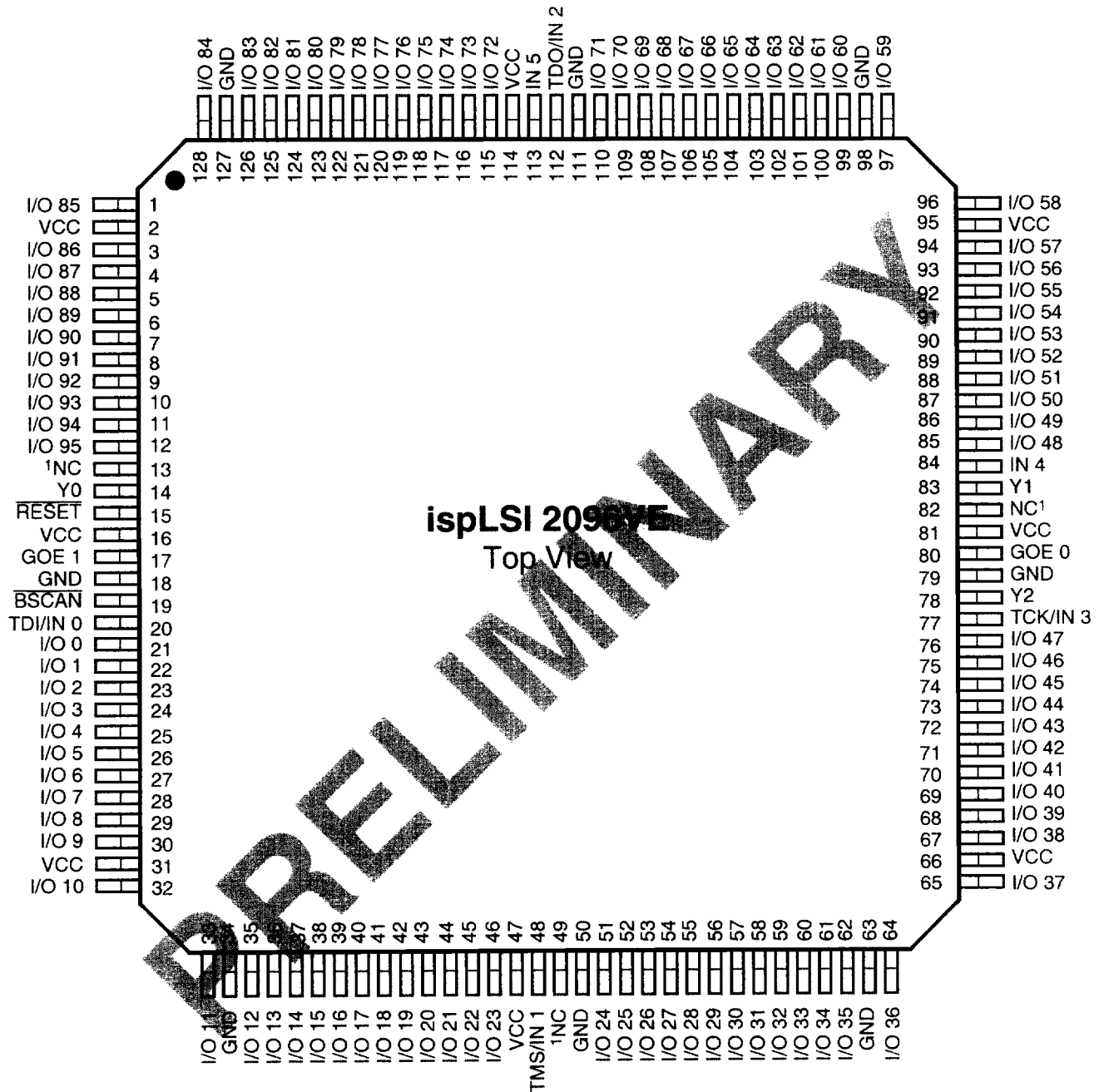

1. NC pins are not to be connected to any active signals, VCC or GND.

## Part Number Description

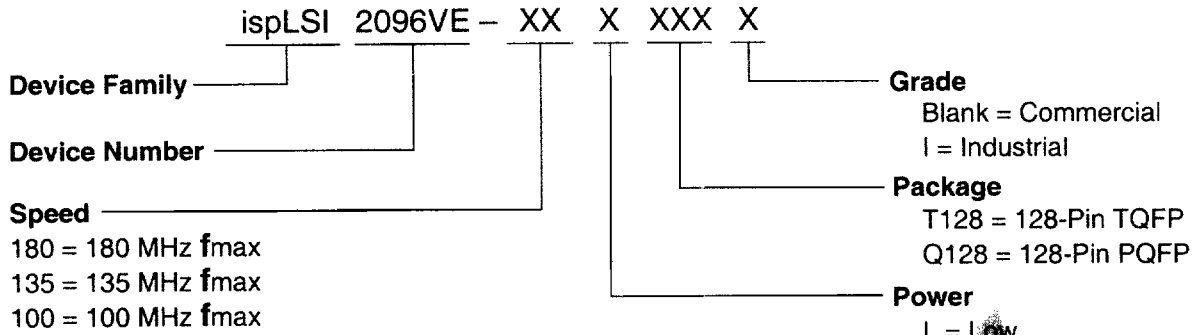

0212/2096VE

## ispLSI 2096V Ordering Information

### COMMERCIAL

FAMILY	<i>f</i> <sub>max</sub> (MHz)	<i>t</i> <sub>pd</sub> (ns)	ORDERING NUMBER	PACKAGE
ispLSI	180	5.0	ispLSI 2096VE-180	128-Pin TQFP
	180	5.0	ispLSI 2096VE-180LQ128	128-Pin PQFP
	135	7.5	ispLSI 2096VE-135LT128	128-Pin TQFP
	135	7.5	ispLSI 2096VE-135LQ128	128-Pin PQFP
	100	10	ispLSI 2096VE-100LT128	128-Pin TQFP
	100	10	ispLSI 2096VE-100LQ128	128-Pin PQFP

Table 2-0041A/2096VE

### INDUSTRIAL

FAMILY	<i>f</i> <sub>max</sub> (MHz)	<i>t</i> <sub>pd</sub> (ns)	ORDERING NUMBER	PACKAGE
ispLSI	135	7.5	ispLSI 2096VE-135LT128I	128-Pin TQFP

Table 2-0041B/2096VE

PRELIMINARY